

# STRATEGIC UNCERTAINTY AVERSION IN BARGAINING

## - EXPERIMENTAL EVIDENCE\*

BEN GREINER<sup>†</sup>

APRIL 22, 2016

### ABSTRACT

In a series of four experiments I demonstrate the existence of significant aversion to basically non-existent strategic uncertainty in very simple bargaining games. This aversion goes far beyond ordinary risk or ambiguity aversion. Specifically, although almost nobody expects or chooses the rejection of an offered equal split in a bargaining game, participants behave as if there would be a considerably large rejection rate for equal splits. This behavior is robust across experimental designs and subject pools, can lead to inefficiencies in markets, and is incompatible with consistency of strategies and rational beliefs.

*Keywords:* strategic risk, strategic uncertainty, ultimatum game, dictator game, impunity game, bounded rationality

*JEL Classification:* C72, C92, D3

---

\*I would like to thank Gary Bolton, Ido Erev, Gigi Foster, Werner Güth, Muriel Niederle, Axel Ockenfels, Michael Peters, Carlos Pimienta, Al Roth, Patrick Schneider, Ro'i Zultan, participants at the ESA Meetings 2004 in Erfurt, 2009 in Tucson, and 2010 in Copenhagen; participants at the TIBER workshop 2010 in Tilburg, and the UNSW Behavioral Economics Workshop 2012; and participants at seminars at ANU, Deakin U, Harvard U, Humboldt U, U Canterbury, U Cologne, U Jena, UNSW Sydney, U Queensland, U South Australia, for the discussions and valuable comments. I am grateful to Bettina Bartels, Susanne Büchner, René Cyranek, Xavier del Pozo, Håkan Fink, Sven Fischer, Ralica Gospodinova, Martin Jonas, Felix Lamouroux, Katinka Pantz, Karin Ruëtz, Carsten Schmidt, and Thomas Wolfarten for their support for the experiments.

<sup>†</sup>University of New South Wales, School of Economics, UNSW Sydney NSW 2052, Australia, Tel: 61 2 938 59701, e-mail: bgreiner at unsw.edu.au.

## I INTRODUCTION

Strategic uncertainty is the risk that players face with respect to the strategies that other players choose.<sup>1</sup> In Nash (1951)'s equilibrium notion there exists no strategic uncertainty: in equilibrium, all players respond optimally to the strategies chosen by the other players. Consequently, in equilibrium beliefs about other's strategy choices must be correct; each player knows with certainty which (probability distribution over) strategies the other players are going to choose.

In this paper I provide robust experimental evidence of a behavioral pattern in simple one-shot bargaining experiments, which suggest the existence of strategic uncertainty and a very strong aversion against this uncertainty. Specifically, I find that subjects behave as if their counterparts would respond in an irrational way, even though in fact they do not. Thus, the aversion I observe is irrational, as it is toward an uncertainty that basically does not exist—either in elicited beliefs or in observed actions. As such, it is incompatible with any equilibrium concept that requires the consistency of strategies and beliefs.

The main result of my experiments is given in Figure 1, which displays binary versions of five two-player games: the *Ultimatum* game (Güth, Schmittberger and Schwarze, 1982), the *Dictator* game (Forsythe, Horowitz, Savin and Sefton, 1994), the *Impunity* game (Bolton and Zwick, 1995), and two variants of the Impunity game — the Symmetric Impunity game and the Reverse Impunity game. These games differ only in the rejection power of the second mover (the payoffs are shown in the boxes in Figure 1). The percentages displayed along the 'up' choice of player 1 denote the percentages of experimental subjects choosing the unequal split in Experiment 1 (all participants made decisions for all games, see Section II). The numbers in the parentheses in Figure 1 show data from different subjects who participated in either the *Ultimatum* or the *Reverse Impunity* game in Experiment 3 (see Section IV).

First, compare the *Impunity* game (upper row left) to the *Symmetric Impunity* game (upper row center). The only difference between these two games is whether the proposer's payoff, in the case of rejection of the equal split offer, is 0 or still 50. More than 10% of the unequal split proposers in the *Impunity* game switch to the equal split in the *Symmetric Impunity* game. Second, compare the *Ultimatum* game (lower row right) to the *Reverse Impunity* game (upper row right). Again, the only difference between these two games is whether the equal split payoff of the proposer can be rejected or not. Between one-third and one-half of the participants who chose an unequal split in the *Ultimatum* game offer an equal split in the *Reverse Impunity* game. At the same time, however, (almost) nobody rejected an equal split, and Experiment 2 (Section III) provides evidence that people also do not expect others to reject an equal split.

---

<sup>1</sup>I assume a very general notion of strategic uncertainty here, the exact meaning in the context of this paper will become clear below. Other terms have been used to coin the specific uncertainty involved in strategic decisions. Roth (1977*a,b*) was among the first to conceptually distinguish the utility of economic agents with respect to 'ordinary risk' (which originates from the chance move in lotteries) from 'strategic risk' (which originates from the interaction with other strategic players). Chateauneuf, Eichberger and Grant (2007) model strategic ambiguity aversion on top of strategic risk attitudes (which represent regular von Neumann-Morgenstern risk preferences). I will discuss their model in Section VI. The term strategic uncertainty has also been used in contexts other than the one discussed in this paper, for example to describe the uncertainty that players face in equilibrium selection problems.

FIGURE 1: THE FIVE EXPERIMENTAL GAMES

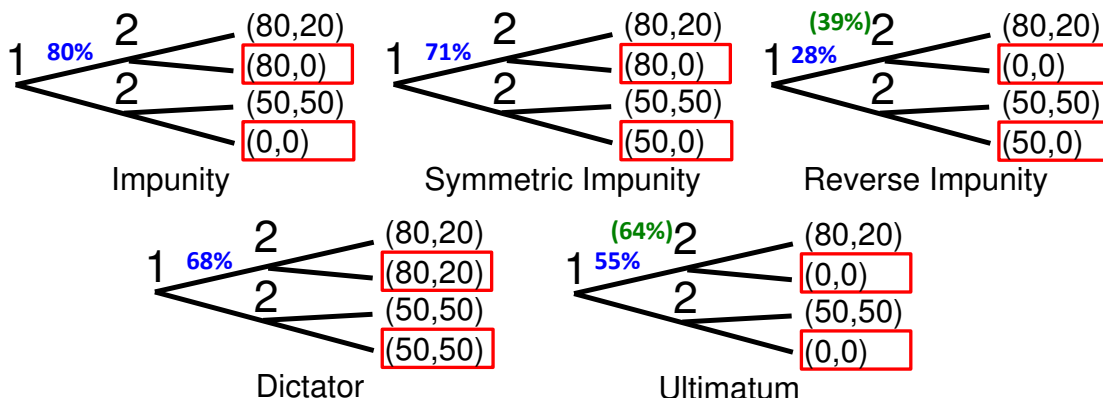

Note: The percentages not in parentheses denote the share of first movers moving ‘up’ in Experiment 1. The percentages in parentheses denote the behavior in these games in Experiment 3.

These results cannot be explained by a theory that assumes consistency of beliefs and actions. This presents a challenge to rationalizing these observations from an economist’s perspective. For example, Bolton and Zwick (1995) compared behavior in the *Ultimatum* game and the *Impunity* game. They expected more unequal splits in the *Impunity* game, but also fair offers, similar to what is usually observed in the Dictator game (see, for instance, Forsythe et al., 1994). To their surprise, they observed almost 100% of equilibrium play in the *Impunity* game.<sup>2</sup> However, Bolton and Zwick (1995, p. 112) did not believe that the asymmetry in equal split rejectability could have driven their result, and wrote:

‘We might also consider the argument that first movers desire fairness but that they opt for the higher payoff in Impunity because they fear that second movers will turn down an offer of the equal split, a risk that is not taken if the higher payoff is chosen. But we see no reason why the first mover would think that the second mover would turn down the equal split.’

In other words, since turning down an equal split offer is neither expected nor observed, it is difficult to explain why proposers should consider the rejectability of the equal split in their deliberation. The results reported in this paper indicate that a good explanation is still needed.

The paper will proceed as follows: In the strategy method experiment reported in Section II I study the five simple bargaining games shown in Figure 1. I qualitatively replicate the results of Bolton and Zwick (1995) for the *Ultimatum* game and the *Impunity* game. Using a *Symmetric Impunity* game, I show that the existence of an option to reject the equal split in the *Impunity* game indeed has a significant impact on the observed proposer behavior compared to the *Dictator* game. I show a similar and even more striking result in a complementary variation of the *Ultimatum* game. Overall, I find that approximately 36% of proposers behave *as if* a non-negligible share of responders would reject an equal split. Section III reports on a second experiment with different participants recruited

<sup>2</sup>This result in Bolton and Zwick (1995) was the initial motivation to conduct Experiment 1 reported in this paper.

from the same subject pool, to determine the expectations of behavior in the five games. The main result is that people expect that responders would not reject an equal split, but also expect that many proposers behave as if that would be the case. The third experiment (Section IV) replicates the results for the *Ultimatum* and *Reverse Impunity* games in a one-shot ‘play method’ (as opposed to a strategy method) environment. This experimental design also allows the measurement of indifference curves with respect to the strategic uncertainty involved in bargaining proposals. Finally, Experiment 4 (Section V) shows that the aversion to strategic uncertainty may lead to social inefficiencies, as people refrain from entering negotiations in favor of less efficient, but strategically safe outcomes. Section VI provides a discussion of the results and relates them to existing economic models and other evidence. Section VII concludes with a summary of the findings and suggestions for future research.

## II EXPERIMENT 1 - A STRATEGY METHOD EXPERIMENT

The first experiment tested five simplified ‘cardinal’ bargaining games, which differ only in the rejection power of the responder: one *Dictator* game, three *Impunity* games and one *Ultimatum* game. Figure 1 above shows the extensive forms of these games. The *Impunity* game (upper row left) is a replication of Bolton and Zwick’s (1995) original game of the same name. After player 1 has chosen between an equal and an unequal split of the pie, player 2 can accept or reject this offer. When player 1 chooses an unequal split, player 2 can only reject her own income, but cannot diminish player 1’s income. When player 1 proposes an equal split, a rejection by player 2 leads to zero payoffs for both players.

In the *Dictator* game (lower row right in Figure 1), player 2 must accept player 1’s offer and cannot change the payoff distribution by choosing up or down.<sup>3</sup> The next game (upper row center) is a *symmetric* version of the original *Impunity* game. Compared to the latter, player 2 now also loses rejection power for an equal split, i.e. if she rejects an equal split offer, player 1 still receives his proposed share, while player 2 receives zero payoff.

In the *Ultimatum* game (lower row right), player 2 has full rejection power for both possible offers. If player 2 accepts an offer, then both players receive the share that player 1 proposed. If player 2 rejects, both players receive zero payoff. Finally, in the *Reverse Impunity* game, the asymmetric rejection power of the original *Impunity* game is flipped. Player 2 can only reject her own payoff for a proposed equal split, while she has full rejection power for both players’ payoffs if an unequal split is chosen. Note that the only difference to the *Ultimatum* game is the rejection power in response to an equal split.

When the rejectability of the equal split is assumed to be irrelevant for proposers (since there is no reason for a responder to reject an equal split), the same number of proposers offering the unequal split in *Impunity* and *Symmetric Impunity* is expected. The same hypothesis is derived with respect to *Ultimatum* and *Reverse Impunity*. If, in contrast, the equal split rejectability plays a role for proposer behavior, then there may be more unequal split offers in *Impunity* than in *Symmetric Impunity*, and in *Ultimatum* than in *Reverse Impunity*. The *Dictator* game was included in the experimental design

---

<sup>3</sup>Although in this game the forking of the game tree in the second stage is redundant, it is shown for comparability with the other figures and for identical experimental instructions across games.

to verify that Bolton and Zwick’s (1995) *Impunity* game results were indeed due to the asymmetry in rejection power. There should be no difference in play between *Dictator* and *Symmetric Impunity*.

Based on the numerous consistent experimental results in the literature on *Dictator* and *Ultimatum* games, I expect less unequal splits and more unequal split rejections in games with unequal split punishment power for the responder (*Ultimatum* and *Reverse Impunity*) than in games with no such power (*Impunity*, *Dictator*, and *Symmetric Impunity*).

Since all games consist of binary choices, the strategy method (Selten, 1967) was used to obtain a large dataset of decisions in all games.<sup>4</sup> In particular, each of the 145 participants made decisions in all five games, both in the role of the proposer and in the role of the responder.<sup>5</sup>

Table 1 shows the observed frequencies of unequal split proposals and the acceptance rates for unequal and equal splits for the five games. There were 67.6% unequal split proposals in the *Dictator* game, compared to 55.2% in the *Ultimatum* game. The difference is consistent with observations in previous studies of Ultimatum and Dictator games. As expected, there are no significant differences between the *Dictator* game and the *Symmetric Impunity* game, with 67.6% and 71.0% unequal split proposals, respectively.

TABLE 1: FREQUENCIES OF UNEQUAL SPLIT PROPOSALS AND ACCEPTANCE RATES IN THE FIVE GAMES

Game	Uneq. Split Proposals	Uneq. Split Acceptance	Equal Split Acceptance
Impunity	0.800	0.986	1.000
Dictator	0.676		
Symmetric Impunity	0.710	0.979	0.979
Ultimatum	0.552	0.910	0.993
Reverse Impunity	0.283	0.938	0.993

However, more people offer an unequal split in the *Impunity* game — where the responder has punishment power for the equal split — than in the *Dictator* game and the *Symmetric Impunity* game. On the other hand, in the *Reverse Impunity* game, where the responder can only reject the unequal split but not the equal split, only 28.3% of the proposers choose the unequal split, which is much lower than in the *Ultimatum* game. In other words: the *Symmetric Impunity* game has 9% more participants offering an equal split compared to the *Impunity* game, and the *Reverse Impunity* game has 26.9% more participants offering the equal split compared to the *Ultimatum* game. In both pairs of games, the only difference is whether the responder can reject an equal split.

To test for statistical significance of these results, a Cochran’s Q test was conducted on the frequencies of unequal split proposals in all five games. A p-value of  $< 0.001$  indicates that at least one proportion differs from the others. Table 2 reports the results of pairwise McNemar tests between

<sup>4</sup>For a discussion of effects of using the strategy method, see Brandts and Charness (2011). In none of their surveyed experiments, a treatment effect detected with the strategy method was absent when using the play method. Section IV will show that my results obtained with the strategy method hold when obtained with the play method.

<sup>5</sup>Appendix A contains a detailed account of the experimental procedures, instructions and questionnaires for Experiment 1.

choice frequencies in different games. The test statistics confirm that the proportion of unequal split proposals is significantly larger in *Impunity* than in *Dictator* and *Symmetric Impunity*. There is no statistically significant difference between *Dictator* and *Symmetric Impunity*, but both have significantly more unequal split proposals than the *Ultimatum* game. Finally, the difference between *Ultimatum* and *Reverse Impunity* game is also statistically significant.

TABLE 2: TEST STATISTICS FOR PAIRWISE MCNEMAR TESTS  
ON THE SHARE OF UNEQUAL SPLIT PROPOSALS

	$N = 145$	Chi-Square	p
Impunity & Dictator		6.881	0.009
Impunity & Symmetric Impunity		4.364	0.037
Dictator & Symmetric Impunity		0.457	0.499
Dictator & Ultimatum		6.283	0.012
Symmetric Impunity & Ultimatum		9.878	0.002
Ultimatum & Reverse Impunity		25.333	0.000

With respect to acceptance behavior, the proportion of responders accepting an unequal split is relatively high in all games in this experiment. In the games with full rejection power for an unequal split, *Ultimatum* and *Reverse Impunity*, there is a rejection rate of 9% and 6.2% for the unequal split offer, respectively, while there is a small rejection rate of 1.4% and 2.1% for *Impunity* and *Symmetric Impunity*, respectively, where the responder can only reject his own share of an unequal split. No statistically significant differences were found between *Ultimatum* and *Reverse Impunity* ( $p = 0.344$ ), and between *Impunity* and *Symmetric Impunity* ( $p = 1.000$ ). On the other hand, rejection rates in *Impunity* and *Symmetric Impunity* are significantly lower than in *Ultimatum* ( $p < 0.01$  for both comparisons). The rejection rate in *Impunity* is lower than in *Reverse Impunity* ( $p = 0.039$ ), while the difference between *Symmetric* and *Reverse Impunity* is not statistically significant at a reasonable level.

Regarding the acceptance rate of the equal split, no statistically significant differences can be found between the games. In *Impunity*, all participants accepted the equal split, and in *Symmetric Impunity*, *Ultimatum* and *Reverse Impunity* only 3, 1 and 1 out of 145 participants rejected the equal split, respectively.<sup>6</sup>

In summary, Experiment 1 shows that it is relevant to proposers whether an equal split is rejectable, even though almost no participants rejected an equal split. This raises the question of whether participants hold incorrect beliefs about the behavior of the responder, or whether beliefs are correct but are not processed in a ‘rational’ way when making choices in the game. The results presented in the next section empirically support the latter answer.

<sup>6</sup>There was one person who rejected the equal split in all three games. Regarding beliefs, most people predicted correctly when asked (in a non-incentivized way) which option they believe the majority of participants would choose. Experiment 2 was specifically designed to examine expectations in the five games.

### III EXPERIMENT 2 - MEASURING BELIEFS

A second experiment was conducted to assess the role of beliefs in the behavior observed in the first experiment. Approximately two years after the first experiment, I conducted an experiment with 153 participants from the same subject pool at the University of Jena, none of whom had participated in the first experiment. Participants received complete information about Experiment 1, including the instructions used and a brief description of the experimental procedures. Then they were asked to predict the average behavior for each game and role, and were paid according to the accuracy of their predictions.<sup>7</sup>

FIGURE 2: DISTRIBUTIONS OF EXPECTATIONS OF AVERAGE BEHAVIOR

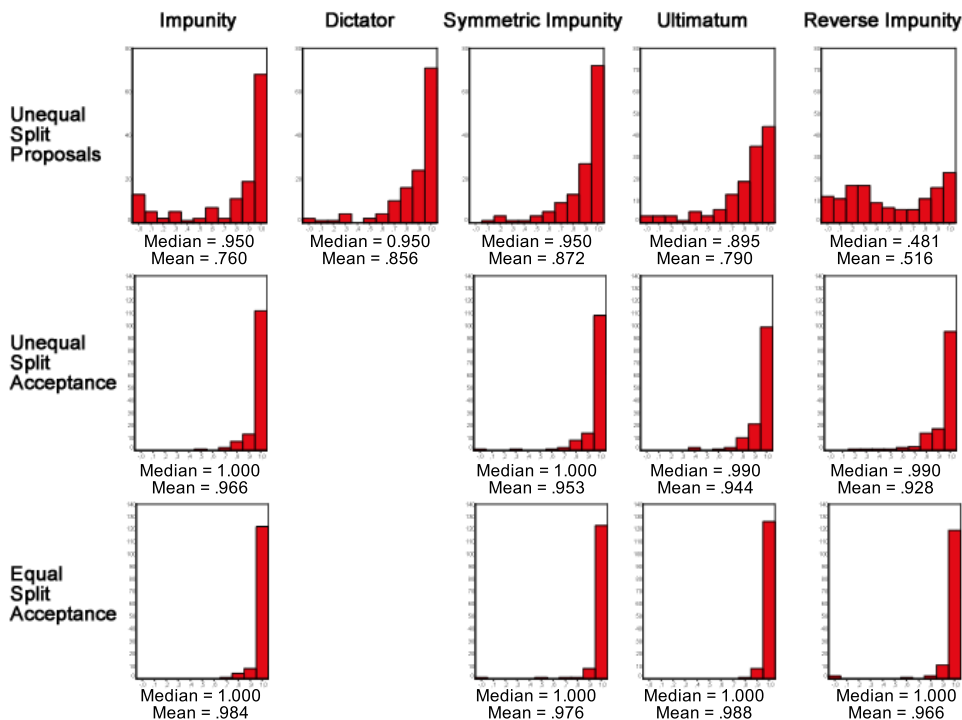

The mean, median, and distribution of the predictions for all games are shown in Figure 2. Although higher in general, the mean predictions of the unequal split frequencies in Experiment 2 follow the order of the actual frequencies in Experiment 1.<sup>8</sup> The distributions reveal a high level of heterogeneity in beliefs about the average proposal behavior. Beliefs about average behavior diverge considerably — especially in the *Ultimatum* game and the *Reverse Impunity* game. Given this uncertainty, the most appropriate statistics would be a simple Sign-Test for related samples. This test reveals comparative statics at the individual level. That is, whether most people think that a lower

<sup>7</sup>Belief elicitation was incentivized using a step-wise payoff function that roughly followed a quadratic scoring rule. Refer to Appendix B for a detailed description of the procedures and instructions.

<sup>8</sup>One notable exception is the relatively low mean expected frequency of unequal proposals for the *Impunity* game compared to the *Dictator* game and the *Symmetric Impunity* game. However, statistically the distributions of predictions for *Impunity* are not significantly different to the distributions for the other two games, and there is no difference in the median prediction across the three games. The lower mean in *Impunity* may be because of a higher number of “0%” predictions due to confusion, while the number of “100%” predictions reached the same level in all three games.

share of participants choose an unequal split in game X compared to game Y. The test therefore ignores the extent of differences and population means. Table 3 shows the results of two-sided Sign Tests on trends in the expected unequal split rates. No agreement was found among participants regarding the order of unequal split rates between the *Impunity* game, the *Dictator* game, and the *Symmetric Impunity* game. However, compared to these three games, most people believe that unequal split rates are lower in the *Ultimatum* game, and lower in the *Reverse Impunity* game than in *Ultimatum* game.

TABLE 3: RESULTS FROM TWO-SIDED SIGN TESTS  
ON THE EXPECTED SHARES OF UNEQUAL SPLIT PROPOSALS

	$N = 135$	Pos	Neg	Ties	Z	p
Impunity - Dictator		53	54	28	0.000	1.000
Impunity - Symmetric Impunity		50	55	30	-.390	.696
Dictator - Symmetric Impunity		58	42	35	-1.500	.134
Impunity - Ultimatum		77	44	14	-2.909	.004
Dictator - Ultimatum		75	42	18	-2.958	.003
Symmetric Impunity - Ultimatum		77	33	25	-4.100	.000
Ultimatum - Reverse Impunity		93	25	17	-6.168	.000

With respect to the acceptance rates, there are surprisingly few participants who expect a significant number of unequal split rejections in the *Ultimatum* and *Reverse Impunity* game, where the responder has strategic punishment power for the unequal split. These low numbers, however, correspond to the relatively low rejection rates observed in Experiment 1. Nevertheless, acceptance rates in *Ultimatum* and *Reverse Impunity* are predicted by participants to be significantly lower than in *Impunity* and *Symmetric Impunity* (Sign Tests,  $p < 0.01$  for all comparisons), while there are no statistically significant differences within these two pairs of games. The predicted acceptance rates of equal splits are high, with no significant trends (except that people seem to expect a higher rejection rate in *Reverse Impunity* than in *Symmetric Impunity*, which is surprising given that both imply choosing a 50/0 split instead of a 50/50, Sign Test: Pos 28, Neg 8, Ties 99,  $p = 0.020$ ).

In summary, almost 70% of the participants in Experiment 2 expected an extreme equal split acceptance rate of 100% in *Impunity* and *Ultimatum*, more than 95% of the participants expected an equal split acceptance rate of greater than 90% in these games. These beliefs cannot justify the treatment effects found for first mover behavior in Experiment 1, namely that removing the rejectability of an equal split leads to more equal split proposals. Interestingly, the participants also expected this inconsistency in the proposer behavior.<sup>9</sup> Predictions of the first mover behavior show a high variance, but generally are in line with the observed choices in Experiment 1. Specifically, the difference in the proposer behavior between *Ultimatum* and *Reverse Impunity* is strong both in actions (Experiment 1) and in beliefs (Experiment 2). These two games are examined further in the experiments reported in the following sections.

<sup>9</sup>Even if the analysis is restricted to participants who expected 100% equal split acceptance in all four games, about the same means and distributions of expectations of proposer behavior as displayed in Figure 2 are found, which are inconsistent with their equal split rejection rate expectations.



#### IV EXPERIMENT 3 - A PLAY METHOD EXPERIMENT

The strategy method experiment (Experiment 1) showed the existence of strategic uncertainty aversion in simple bargaining games. The elicitation of beliefs in Experiment 2 suggests that beliefs follow the same pattern as behavior. This demonstrates the robustness of the results, especially for the comparison between the *Ultimatum* game and the *Reverse Impunity* game. The third experiment replicates these two experimental games in a play-method environment. That is, each subject participates only in one game and in one role. In addition, indifference curves with respect to submitted *Ultimatum/Reverse Impunity* proposals are measured.

Four experimental sessions were conducted in the Computer Laboratory for Economic Research at the University of Cologne, two sessions for each of the games. There were 214 participants in total.<sup>10</sup> At the beginning of each session, participants were randomly assigned to the role of the proposer or the responder. The responders were sent to a different room and received their experimental instructions only after the proposers made their decisions as described below. Proposers received *Ultimatum* or *Reverse Impunity* instructions and were asked for their proposal: either an equal or an unequal split of 15 Euros. After the proposers made their decision, they received additional instructions. Each proposer was offered the opportunity to stop the game at this point and to implement a Dictator game with safe payoffs instead, where the responder has no decision to make and can only accept the offer. Specifically, proposers were shown 49 different distributions of proposer and responder payoffs, in random order. For each of these safe payoff distributions, the proposer was asked whether he would change to this safe payoff combination or continue with the original *Ultimatum/Reverse Impunity* game. After these choices were made, one of the 49 safe payoff distributions was selected randomly. If the proposer had previously stated to cancel the original game for this safe payoff distribution, then the responder is informed that that the proposer had selected this payoff distribution, and she has no decision to make. If the proposer had previously chosen to continue with the original game, then the responder received the *Ultimatum/Reverse Impunity* instructions, was informed about the proposer's offer and made her decision.<sup>11</sup>

The grid of 49 safe payoff distributions offered to the proposer differed according to whether the proposer had chosen an unequal split and or an equal split in the original game. Figure 3 shows these two grids in the proposer-responder payoff space. By offering proposers these payoff combinations after they made their proposal, their indifference curve to this (subjectively risky) proposal was measured in the space of safe payoffs. The location and slope of indifference curves should reflect the proposer's (social) preferences and their rejection risk assessment for their proposal. A typical inequality aversion indifference curve, for example, would be asymmetrically U-shaped, with the minimum at its

---

<sup>10</sup>For a detailed description of the experimental procedures and instructions please refer to Appendix C.

<sup>11</sup>This procedure may have a "smell of deception", since proposers were not made aware of the subsequent choices for additional outside options when making their proposal. However, informing proposers about the procedure in advance might bias their proposals (which were the main subject of interest), and the additional outside options did not negatively affect participants' payoff prospects. Thus, after thorough consideration of the involved trade-offs I decided to implement this procedure. Please note that responders were not deceived since they received game instructions only after proposers made their choices.

FIGURE 3: GRIDS OF OFFERED PAYOFF COMBINATIONS,  
CONDITIONAL ON THE PROPOSER'S CHOICE

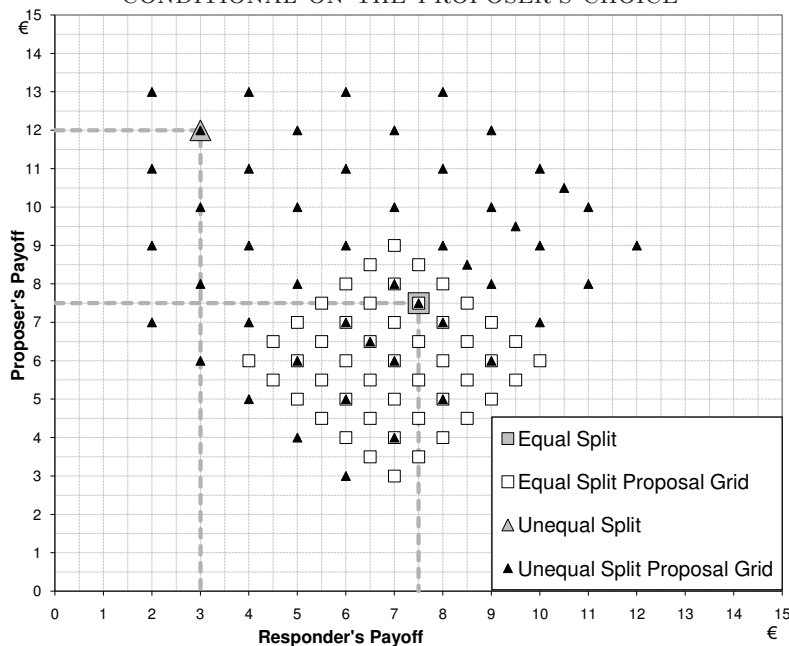

intersection with the 45 degree line. The indifference curve of a pure egoist would be a horizontal line. If the proposal involves any perceived risk with respect to rejection, or other types of strategic uncertainty, then the indifference curve would be located *below* the position of the corresponding Ultimatum proposal in the grid.

Based on the observations in Experiment 1, less proposers were expected choose the unequal split in the *Reverse Impunity* game than in the *Ultimatum* game. Proposers who choose the unequal split in the *Ultimatum* game were expected to switch to a Dictator game with safe payoffs lower than or equal to the equal split outcome (i.e. accept payoff combinations in the square opened up between (0,0) and the equal split (7.5,7.5) in Figure 3). In other words, there will be unequal-split-proposers who accept payoff distributions dominated by the equal split even though they had the opportunity to offer an equal split in the first place (but the responder had the possibility to reject that offered equal split). I do not expect any of the unequal split choosers in the *Reverse Impunity* game would do this, since they already had the option to switch to a safe equal split when making their offer.<sup>12</sup>

Decisions from 56 *Ultimatum* pairs and 51 *Reverse Impunity* pairs were collected. As some of the offered safe payoff combinations were accepted, the number of observations for responders is lower than the number of proposers. Table 4 lists the frequencies of proposals and responses, as well as results from Fisher's Exact Tests on statistical differences in the choice distributions.

<sup>12</sup>It is difficult to make any reasonable predictions for the switching behavior of proposers who chose the equal split in the first place. In *Ultimatum*, even if they have choose the equal split despite its rejectability, they might still prefer a lower, but safe outcome. Even in *Reverse Impunity*, the fair proposers might fear that the responder will reject her own share of an equal payoff split, and may try to prevent this. In the analysis below, I focus on indifference curves with respect to unequal split proposals.

TABLE 4: CHOICE FREQUENCIES FOR EXPERIMENT 3

		Ultimatum		Reverse Impunity		Fisher's Exact Test
						p-value
<i>Proposed</i>	Unequal Split	36	(64%)	20	(39%)	0.012
	Equal Split	20		31		
<i>Equal split</i>	accepted	15	(94%)	24	(100%)	0.400
	rejected	1		0		
<i>Unequal split</i>	accepted	16	(70%)	13	(87%)	0.273
	rejected	7		2		

FIGURE 4: SWITCHING DECISIONS AND MEDIAN INDIFFERENCE CURVES AFTER UNEQUAL SPLIT PROPOSALS

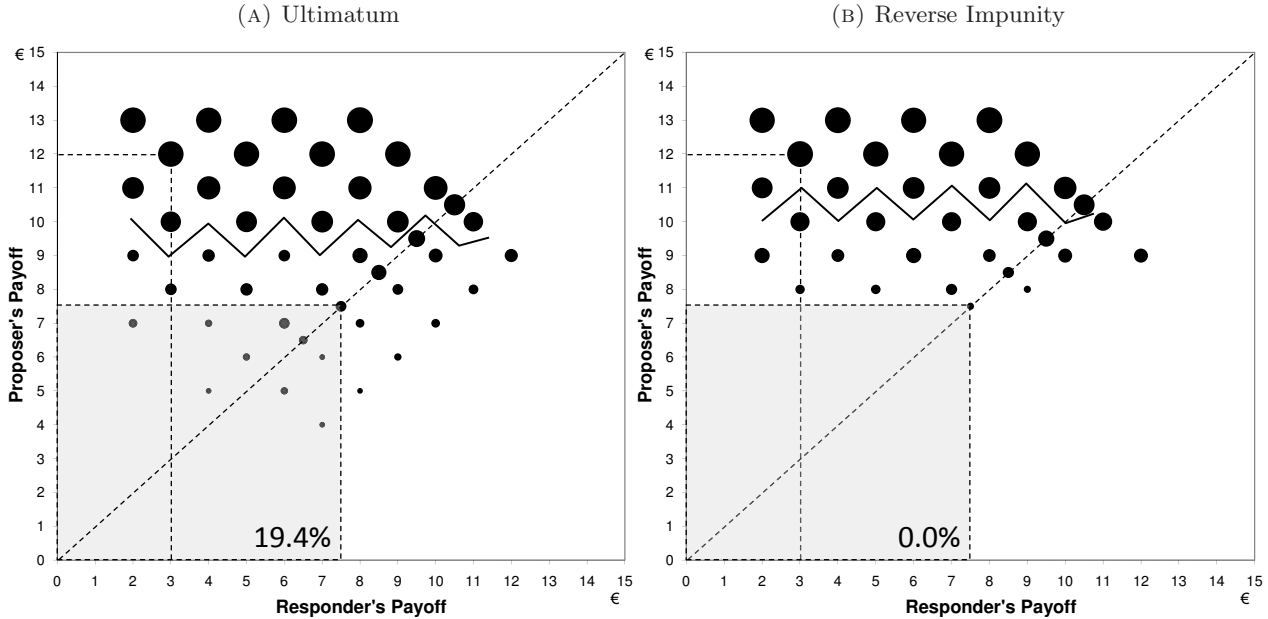

Note: The size of the circles (area) represents the relative frequency of acceptance choices. The percentages denote the share of proposers who accepted at least one payoff combination that was strictly Pareto-dominated by the equal split (7.5,7.5). The solid lines show the ‘median indifference curve,’ parting acceptance rates above and below 50%.

The results for proposal rates in Experiment 3 replicate the findings in Experiment 1. A significantly fewer number of proposers (39%) chose the unequal split in the *Reverse Impunity* game than in the *Ultimatum* game (64%). This provides evidence for the robustness of the results obtained with the strategy method in Experiments 1 and 2. No significant differences are found between acceptance rates in the *Ultimatum* game and the *Reverse Impunity* game, both for equal and unequal splits.<sup>13</sup>

Figure 4 shows the frequencies of acceptances of safe payoff distributions in the proposer/responder payoff space, when offered as an alternative to a chosen unequal split. My hypothesis was confirmed: while about 20% of those who propose the unequal split in the *Ultimatum* game accept at least one safe payoff combination which is strictly Pareto-dominated by the equal split (7.5,7.5), none of the ‘unfair’

<sup>13</sup>Note, however, that the acceptance rate for the *Ultimatum* equal split was not 100%. The participant responsible for this result approached me after the experiment and explained that he had misunderstood the instructions.

proposers in the *Reverse Impunity* game did so. Figure 4 also shows the median indifference curves in the safe payoff space with respect to the offered (potentially rejected) proposal.<sup>14</sup> As expected, the median indifference curve of unequal split proposers in the *Ultimatum* game lies above the median indifference curve of those who choose the unequal split in the *Reverse Impunity* game. The curves are almost horizontal lines (rather than U-shaped or at least falling in the space above the 45 degree line), indicating that the median proposer cares little about responder payoffs.<sup>15</sup>

In summary, the between-subjects ‘play method’ in Experiment 3 replicates the findings from the within-subjects strategy method in Experiment 1. There are significantly more proposers choosing to offer an equal split in the *Reverse Impunity* game than in the *Ultimatum* game. The switching behavior with respect to offered safe payoff distributions is consistent with that observation.

## V EXPERIMENT 4 - SOCIAL COSTS OF STRATEGIC UNCERTAINTY AVERSION

The fourth experiment demonstrates that the strategic uncertainty aversion evidenced in the first three experiments can have social costs. Specifically, strategic uncertainty aversion might lead participants to not enter negotiations if less efficient, but safe outside options are available. This experiment involved simple variants of the *Ultimatum/Reverse Impunity* games, where participants could choose whether they wish to enter the game or not.

Figure 5 depicts the extensive form of the *Ultimatum Entry/Reverse Impunity Entry* games. Both Participant A and Participant B can choose to enter (‘in’) or not (‘out’). If both participants choose ‘out’, then each receives a safe payoff of \$20. If one participant chooses ‘in’ and the other chooses ‘out’, then the participant who chooses ‘in’ becomes the proposer, while the other participant takes the role of the responder. If both decide to enter, then a random draw is used to determine the roles.

As before, the proposer then chooses between offering an equal split or an unequal split, and the responder decides to accept or to reject the offered split.<sup>16</sup> In the *Ultimatum* game, the responder may reject the equal split. In contrast, in the *Reverse Impunity* game, the responder cannot reject an equal split.

Both versions of the game have only one equilibrium which survives backward induction or repeated elimination of weakly dominated strategies: the one where both players play (In, Selfish, Accept, Accept). Thus, standard game theory (assuming selfishness and the capability to induct backwards) predicts that there should be no ‘out’ choices.<sup>17</sup>

<sup>14</sup>The median indifference curve was obtained by drawing a line between the payoff combinations which were accepted by more than 50% of the proposers and the combinations that were accepted by less than 50% of the proposers. Another way to aggregate individual preferences is to weigh payoff distributions by the acceptance frequencies.

<sup>15</sup>No differences are found between games in the switching behavior of proposers of equal splits, about 15% of which, in both games, accepted payoff distributions pareto-dominated by the equal split. The median indifference curves of these equal-split-proposers are naturally located lower than for unequal split proposers, and are slightly falling in the range above the 45 degree line.

<sup>16</sup>Note that the rejection payoff for the unequal proposal is (\$10,\$10) rather than (\$0,\$0). This was implemented to comply with the minimum payment rules for the HBS subject pool, as there was no showup-fee given in this experiment. In addition, in contrast to Experiment 1 and 3, the responder in the *Reverse Impunity* game cannot reject his own payoff for the equal split. However, these changes did not affect the essential game features that are of interest.

<sup>17</sup>There are more pure strategy Nash Equilibria that are not subgame perfect. In the *Reverse Impunity* game, a player

FIGURE 5: THE ULTIMATUM/REVERSE IMPUNITY ENTRY GAME IN EXPERIMENT 4

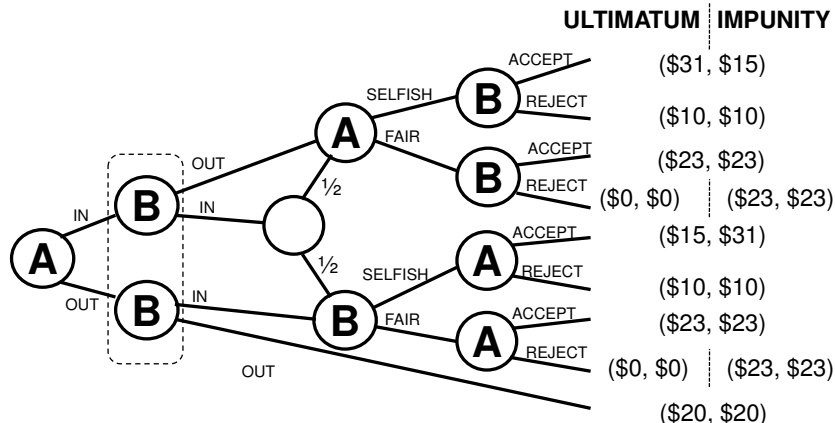

In general, as long as players believe that the other player would not reject an equal split, both games are strategically completely equivalent, for any set of preferences over payoffs. Under this assumption, the null hypothesis is that the number of ‘out’ choices in both games will be the same. However, when the rejectability of the equal split in the *Ultimatum* game matters, i.e. when participants dislike the additional strategic uncertainty of ultimatum bargaining, there might be more ‘out’ choices in *Ultimatum* than in *Reverse Impunity*. Any ‘out’ choices imply (expected) efficiency losses.

TABLE 5: CHOICE FREQUENCIES IN EXPERIMENT 4

		Ultimatum		Reverse Impunity		Fisher’s Exact Test
						p-value
<i>Entry choices</i>	In	37	(56%)	43	(83%)	0.002
	Out	29		9		
<i>Pairs</i>	In	26	(79%)	25	(96%)	0.066
	Out	7		1		
<i>Proposed</i>	Unequal split	20	(77%)	18	(72%)	0.755
	Equal split	6		7		
<i>Unequal split</i>	accepted	15	(75%)	16	(89%)	0.410
	rejected	5		2		
<i>Equal split</i>	accepted	6	(100%)			
	rejected	0				

The experiment was conducted with 66 *Ultimatum* participants and 52 *Reverse Impunity* participants at the Harvard Business School’s Computer Laboratory for Experimental Research (CLER).<sup>18</sup> Table 5 lists the frequencies of in/out choices, unequal/equal split proposals, and acceptances/rejections. While 83% of the participants chose to enter the *Reverse Impunity* game, only

would be indifferent between entering the game or staying out if he firmly believes that the other player would enter the game, propose an equal split, and reject an unequal split (in the role of responder). However, if there is any doubt in these beliefs, then a player should enter. The same is true for the *Ultimatum* Entry Game, but here a player might also stay out if he believes that the other would enter, propose an unequal split, and at the same time reject any offers in the role of responder.

<sup>18</sup>Refer to Appendix D for the experimental procedures and instructions.

56% did so in the *Ultimatum* game (Fisher’s Exact Test,  $p = 0.002$ ). As a result, 96% of the pairs eventually entered the *Reverse Impunity* game, and only 79% of the pairs entered the *Ultimatum* game (a weakly significant difference).<sup>19</sup>

All participants who chose ‘out’ either did not enter the game or were assigned the role of the responder. Correspondingly, the participants for whom the rejectability of the equal split played a role did not become a proposer in the *Ultimatum* game. As a result of this self-selection into game roles, no differences are observed in the actual proposer and responder behavior across the two games. The unequal split proposal rate (77% vs. 72%) and the rejection rate for unequal splits (25% vs. 11%) were slightly higher in the *Ultimatum* game compared to the *Reverse Impunity* game, but these differences are not statistically different.

Both small differences—in the proposal and rejection rates—resulted in an overall conflict rate (cases where value is destroyed through the rejection of an offer) of 19.2% in the *Ultimatum* game, and only 8% in the *Reverse Impunity* game. This difference might be due to an endogenous selection bias, if sensitivity to strategic uncertainty and social preferences are correlated. As ‘out’ choosers never became proposers, this assumption can be tested only for responders in the *Ultimatum* game. Indeed, only 12.5% of those who chose ‘in’ and became the responder rejected an unequal split (1 out of 8), while 33% (4 out of 12) of those who initially did not want to enter turned down an unequal offer. This difference, however, was not statistically significant due to the low number of observations in these cells.

In summary, the rejectability of the equal split can lead to two kinds of inefficiencies in the *Ultimatum Entry* game: first, some pairs do not enter negotiations at all, yielding less efficient outcomes than a successful bargaining solution. Second, due to the self-selection at the entry stage of the *Ultimatum Entry* game, relatively more egoists might enter the game as proposers and more fair-minded people could end up as responders, compared to the *Reverse Impunity* game. This can lead to a higher disagreement rate, implying further efficiency losses.

## VI DISCUSSION

In Experiments 1 and 3, although equal splits are almost never rejected, a non-negligible percentage of people behaves as if there is a non-negligible chance that an equal split will be rejected. Experiment 2 shows that most participants (mode) indeed believe that equal splits are never rejected. Experiment 4 provides evidence that the behavior might lead to sorting and efficiency losses in economic interactions. The observed behavior seems to be robust across different games, subject pools, procedures, and countries.

This section will relate the experimental evidence to the body of behavioral models compiled over the years in economics. It is clear that the behavior cannot be justified in models of rational decision-making and game play, which assume that beliefs are correct in equilibrium and players respond optimally to their beliefs (i.e. any model using Nash Equilibrium as the solution concept). An immediate question is whether participants entertain incorrect beliefs, or whether they have

---

<sup>19</sup>A pair of participants enters the game whenever one of the two participants chooses ‘in’.

correct beliefs but do not respond optimally to them. The results from Experiment 2 suggest that beliefs are mostly correct, and therefore it is the behavioral decision model that is of interest.<sup>20</sup>

### *Social preferences*

Deterministic social utility models incorporating social preferences such as altruism, fairness, or reciprocity (see, among others, Bolton and Ockenfels, 2000; Dufwenberg and Kirchsteiger, 2004; Falk and Fischbacher, 2006; Fehr and Schmidt, 1999; Levine, 1998; Rabin, 1993) cannot explain the behavior I observed in my experiments. One reason is that they still rely on Nash Equilibrium as the solution concept. Another is that they cannot explain rejections of an equal split, and thereby (incorrect) beliefs in such behavior, in the first place.<sup>21</sup>

### *Risk aversion*

While almost everyone accepts an equal split, I also observed outliers. In Experiment 1 (3, 4) one (one, zero) out of 145 (16, 6) participants rejected an offered equal split in the *Ultimatum* game, and in Experiment 2 the average expected equal split rejection rate for the *Ultimatum* game was 1.2% (but the median and mode were 0%). Given the very small, but not necessarily zero probability that someone will reject an equal split, the observed behavior could be rationalized by an extreme form of risk aversion. However, participants were recruited from the usual experimental economics subject pools. There is no reason to believe that they are more risk averse than the participants in the experimental economics literature. The risk aversion necessary to explain a switch from an unequal split in *Ultimatum* to an equal split in *Reverse Impunity*, given elicited expectations or observed probabilities of equal split rejections, is beyond what is usually measured in experimental subject pools for these kinds of stakes.

The risk participants are taking, however, is not like the ordinary risk in chance moves in lotteries. Results from Bohnet and Zeckhauser (2004) suggest that people treat strategic risk (the uncertainty about other players' moves) differently to regular risk. They compare first-mover behavior in a cardinal trust game with behavior in the same game when the second mover is replaced by lottery which implements the same probabilities as observed for trustworthy behavior in the first condition. They show that first movers are more 'trusting' in the lottery game than in the game with a human counterpart. Bohnet and Zeckhauser (2004) interpret this result as evidence for 'betrayal aversion' on the side of the trustee. In my experiments, there is no betrayal, since rejecting an equal split hurts both players, but one may be able to generalize Bohnet and

---

<sup>20</sup>One argument could be that what I observe here is a strategic spillover effect: the non-rejectability of the equal split could have a negative effect on acceptances of the *unequal* split, thereby making the equal split more attractive. But I find no support for this explanation, if at all, then the evidence points in the other direction, as empirically acceptance rates of unequal splits in *Reverse Impunity* are usually higher than in *Ultimatum*.

<sup>21</sup>Note, that reciprocity models such as Rabin (1993) and Dufwenberg and Kirchsteiger (2004) are an exception here. They could explain that responders reject an equal split. Assume that a responder would accept an unequal split but reject an equal split. As rejecting an equal split is unkind to the proposer, proposing the equal split (expecting rejection) is unkind to the responder since proposing the unequal split would make her better off. Thus, the described strategies form an equilibrium in a reciprocity model. But as discussed above, responders almost never reject, so this potential reciprocity equilibrium is simply not played.

Zeckhauser (2004)’s betrayal aversion to ‘strategic risk aversion’ in the gist of Roth (1977*a*)—that people may deal with strategic risk (that is, risk due to the behavior of others) differently to ordinary risk.

### *Errors*

Some behavioral models of game play incorporate the possibility that players make errors when making their choices or when determining the utility consequences of their choices, and that other players know about this (see, for example, McKelvey and Palfrey, 1995, 1998; Rosenthal, 1981).<sup>22</sup> In my experiments, responders actually do not make many errors. Even if it is assumed that proposers believe that responders make errors, the error rate necessary to explain the proposer behavior would be unrealistically high.<sup>23</sup>

### *Heuristics*

Models of boundedly-rational decision-making, such as heuristics, might be an alternative (see, for example, Gigerenzer, Todd and the ABC Research Group, 1999). One example would be an item-wise comparison of choice options. In the *Ultimatum* game, for instance, an offer of an equal split is ‘fair,’ and the unequal split is ‘not fair.’ However, choosing ‘up’ might yield a ‘higher income,’ and choosing down might yield a ‘lower income.’ In the *Reverse Impunity* game, there is an additional item: the personal outcome of choosing ‘down’ is ‘safe,’ and the outcome of choosing ‘up’ is ‘unsafe’ to some extent.

Another heuristic, which simply ignores all strategic properties of the game, would be the computation of unweighted averages over all potential outcomes of an action. Under such a decision heuristic, in the *Ultimatum* game the proposer decides between an average payoff distribution of (40,10) when choosing ‘up’ and (25,25) when choosing ‘down,’ but when confronted with the *Reverse Impunity* game, the choice is between (40,10) for ‘up’ and (50,25) for ‘down’. Figure 6 shows the complete picture. Social utility functions (such as in inequality aversion models) with a preference order of  $u(50, 25) > u(80, 10) > u(25, 25)$  or  $u(50, 25) > u(40, 10) > u(25, 25)$  are easy to find. But such non-strategic heuristic decision-making cannot explain why proposers would be more likely to offer an unequal split in the *Dictator* game (80,20 vs. 50,50) than in the *Ultimatum* game (40,10 vs. 25,25). For that, one needs to take into account of the strategic properties of the game, in particular that the proposer considers the rejection power of the responder in the *Ultimatum* game, something that the simple heuristic does not assume.

---

<sup>22</sup>These models have been shown to be able to capture the data in various games, but were also criticized for capturing too much: in some games they could justify a large range of behavior, thereby losing empirical content (Haile, Hortaçsu and Kosenok, 2008).

<sup>23</sup>Consider a simple ad-hoc decision error model which states that the proposer expects the responder to deviate from his optimal decision with some probability, and that the expected error rate in response to an equal split is the same as in response to an unequal split. In *Ultimatum* both proposals are ‘unsafe’, but in order to prefer a safe equal (50,50) split over an unsafe unequal split (80,20) in *Reverse Impunity*, a risk-neutral proposer’s subjective probability belief that the responder makes an error after an equal split proposal has to be at least 37.5%.



FIGURE 6: PERCEIVED CHOICE VALUES IN THE FIVE GAMES WHEN USING THE AVERAGING

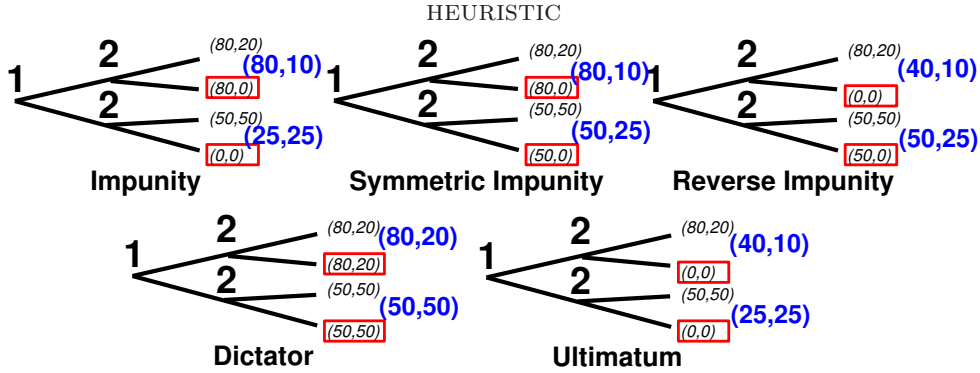

### Limited depth of reasoning

Closely related to decision heuristics are the non-equilibrium level-k reasoning (‘cognitive hierarchy’) models, which relax the assumption of mutual consistency in strategies and beliefs (see Camerer, Ho and Chong, 2004; Costa-Gomes and Crawford, 2006; Stahl and Wilson, 1995, among others). In general, the models assume that there is a non-strategic intuitive or randomizing type  $L_0$ , and that other, higher order types  $L_k$  play best response to types  $L_{k-1}$  or to normalized distributions of types  $L_0$  to  $L_{k-1}$ . With the right type distributions in the population (usually hump-shaped, with small  $L_0$  frequency and mass for  $L_1$  and  $L_2$  types), these models can predict choice distributions in many multi-person games. There is some doubt whether level-k reasoning models are appropriate to explain behavior in bargaining games. First, these models cannot predict non-interactive *Dictator* game behavior except by *assuming* the behavior as  $L_0$  type. Second, for two-person two-stage games like the *Ultimatum* game these models require additional ad-hoc assumptions about the  $L_0$  responder behavior (specifically that responders do not reject an equal or even a more generous split!) in order to yield empirically valid predictions (see Camerer, Ho and Chong, 2002, pp. 17–18).

### Strategic ambiguity

As Selten (2001) points out, in their seminal book, von Neumann and Morgenstern (1944) refrain from modeling explicitly how a player should think about other players. Players are egoistic maximizers, who are only interested in what can be *assured* in an economic interaction. In other words, while a von-Neumann/Morgenstern-player recognizes and reacts to another player’s *options*, she does not think about the actual *strategy* of the other player. In the class of two-person zero-sum games, or more generally in the class of games where each arbitrary pair of players has strictly conflicting interests (‘strictly competitive games’), this assumption yields equilibrium strategies consistent with mixed-strategy Nash Equilibrium. However, outside the world of zero-sum-games, the missing definition of how to see the other player leads to indeterminacy of the behavioral model, and as such gives room to other guides of behavior. This gap was filled by Nash (1951), and most of modern behavioral game theory did not question his assumption of consistency of strategies and beliefs.<sup>24</sup>

<sup>24</sup>Selten (2001) provides a more extensive discussion, but unfortunately only in German.

The experimental evidence presented in this paper suggests that it might be worthwhile to re-examine the early work in game theory. My experimental results suggest that von Neumann-Morgenstern's maximin behavior may actually have some *empirical* content. In the end, maximinizing simply implies extreme pessimism with respect to the choices of the other player.

One way to model maximin behavior in a less extreme way is to introduce it as a preference in the utility function. Recent attempts to capture the intuition of pessimistic, safe-keeping strategic behavior include the model of strategic ambiguity aversion of Chateauneuf et al. (2007). Building on the earlier work on non-additive beliefs, they model players' beliefs as capacities which are additive in intermediate outcomes, but potentially non-additive in the extremes. As a result, a player maximizes a value function such as the one displayed below, which represents a linear weighted average of the regular expected payoff  $E_{\pi_i} u_i(s_i, s_{-i})$  of a chosen strategy  $s_i$  (based on rational beliefs  $\pi_i$  regarding the strategies chosen by other players,  $s_{-i}$ ) and its best and worst outcome of all possible responses of other players. The parameter  $\delta_i$  represents the ambiguity of a player, i.e. how much he trusts his own subjective belief of other players' strategies, and the parameter  $\alpha_i$  represents how optimistic or pessimistic the player is, i.e. how much he considers the best vs. worst possible outcome.

$$V_i(s_i, \pi_i, \alpha_i, \delta_i) = \delta_i [\alpha_i \max_{s_{-i}} u_i(s_i, s_{-i}) + (1 - \alpha_i) \min_{s_{-i}} u_i(s_i, s_{-i})] \\ + (1 - \delta_i) E_{\pi_i} u_i(s_i, s_{-i})$$

Eichberger, Kelsey and Schipper (2008) and Eichberger and Kelsey (2011) apply this concept to experimental games, and find that it is consistent with much of the evidence. In particular, Eichberger and Kelsey (2011) report that experimental results in a number of simple games reported in Goeree and Holt (2001) are consistent with results from a separate estimation of ranges of ambiguity ( $\delta_i$ ) and pessimism ( $1 - \alpha_i$ ) in individual decision-making reported in Kilka and Weber (2001).

For the games reported in this paper, I am able to perform a similar exercise. After fixing the shape of the expected utility function  $E_{\pi_i} u_i$  and beliefs  $\pi_i$  about the responder behavior in the different games, I can test which configurations of  $\delta_i$  and  $1 - \alpha_i$  can explain a switch between offering an unequal split in the *Ultimatum* game and an equal split in the *Reverse Impunity* game. Table 6 lists the estimation results from Kilka and Weber (2001). For my different experimental studies and a set of possible assumptions about beliefs, Table 7 shows whether the strategic ambiguity model with average / maximum Kilka and Weber (2001) values can explain the switching behavior from *Ultimatum* to *Reverse Impunity* game for an otherwise risk-neutral egoistical player, and which values of  $\delta_i$  and  $1 - \alpha_i$  would be necessary to explain such a switch.<sup>25</sup>

Neither the switches in Experiment 1 or in Experiment 3 can be explained with the range of parameters reported in Table 6. In fact, the values necessary to explain the switches in these experiments even exceed the maximum values in the distributions estimated in Kilka and Weber (2001). Only for Experiment 4, the minimum required parameter values lie in the range reported by Kilka and Weber

---

<sup>25</sup>Note that even after fixing utility function and beliefs, the necessary  $\delta_i$  and  $1 - \alpha_i$  are not uniquely identified. In Table 7 I assume them to be equal in order to derive the minimal values required to explain an effect of equal split rejectability.

TABLE 6: ESTIMATED RANGES OF  $\delta_i$  AND  $1 - \alpha_i$  FROM RESULTS IN KILKA AND WEBER (2001)

	$1 - \alpha_i$	$\delta_i$	$\delta_i(1 - \alpha_i)$
Average	0.50	0.52	0.26
Maximum	0.60	0.61	0.37
Minimum	0.38	0.41	0.16

TABLE 7: CAN KILKA AND WEBER (2001) PARAMETERS EXPLAIN SWITCHING BETWEEN *Ultimatum* GAME AND *Reverse Impunity* GAME?

Experiment	Beliefs about responder behavior	K&W Average	K&W Maximum	Minimum $1 - \alpha / \delta$ needed
Exp 1	Observed choices	No	No	0.70 / 0.70
Exp 1	Exp 2 average beliefs	No	No	0.70 / 0.70
Exp 1	Exp 2 median beliefs	No	No	0.71 / 0.71
Exp 3	Observed choices	No	No	0.70 / 0.70
Exp 4	Observed choices	No	Yes	0.58 / 0.58

(2001), and even this is close to the maximum values in the range. Therefore, compared to the decisions of subjects in Kilka and Weber’s (2001) individual decision tasks, and the behavior of subjects in Goeree and Holt (2001), which has been found to be consistent with Kilka and Weber’s (2001) parameter values by Eichberger and Kelsey (2011), my experimental participants seem to feel much more ambiguity about their beliefs and be much more pessimistic in their response to that ambiguity.

Another way to capture the phenomenon could be to introduce a taste for ‘having the last word’—a positive utility component in case an outcome can be completely determined—or, similarly, a positive utility of having a decision-right. Owens, Grossman and Fackler (2014) find that their participants were more likely to bet on themselves answering a quiz question than on a partner, despite contrary (beliefs about) success probabilities, suggesting the existence of a desire for control. Charness and Gneezy (2010), on the other hand, do not find that, when resolving a lottery, people would like to throw dice themselves rather than allowing the experimenter to throw the dice for them, and therefore show no evidence for illusion of control. Fehr, Herz and Wilkening (2013) report evidence for a preference for authority in an experiment where they observed principals refusing to delegate decision rights to agents even when it would be profitable to do so. An explanation they put forward is regret aversion, since in their game the principal may ex-post have been better off to keep the decision right. In our bargaining games, however, regret aversion could only play a role if equal split offers had an empirically substantial chance to be regretted, which is not the case.

Bartling, Fehr and Herz (2014) found a clean way to measure the utility from possessing a decision right in the context of a similar delegation game. In the game, a principal can delegate the right to choose a risky project and invest effort towards its implementation (which determines the success probability of the project) to an agent, or keep that right to herself. Importantly, the principal can condition the transfer of that right on a minimum effort required from the agent. Later, the exper-

imenters elicit valuations over the implied lotteries from delegation and non-delegation.<sup>26</sup> Since the principal should choose a minimum required effort that makes her indifferent between delegation and non-delegation, differences in the independently elicited valuations of the implied lotteries represent a measure of a (positive or negative) preference for having the decision right. The design implicitly controls for risk and social preferences as well as ambiguity aversion. Bartling et al. (2014) report that the majority of subjects are willing to sacrifice expected utility in order to retain the decision right in the delegation game. Importantly, the strategic uncertainty faced by the principal after delegation only consists of an upside risk: the agent may choose a project preferred by the principal, or may provide a higher level of effort than required. Still, the principal seems to value keeping the decision right.

Bartling et al. (2014) term the valuation difference they measure an “intrinsic utility component of being in control”. In the context of the delegation game, this means preferring to choose project and effort level oneself, rather than leaving this choice to someone else (who can be perfectly controlled from the lower bound in terms of payoff implications). With respect to the bargaining games studied here, it is not readily clear how such a definition may apply. Does ‘being in control’ mean to be in the more powerful role of the proposer (no matter what happens after), or is such a position disliked when the responder still has a (perfectly predictable) choice to make? In the latter case, for example, preferences for decision rights are consistent with placing higher value on playing the *Impunity* game than on playing the *Ultimatum* game in Experiment 4. On the other hand, why would a person with preferences for decision rights opt for an outside option in the first place, if that choice nullifies her chances to become the proposer?

In general, the bargaining games studied in this paper cannot separate preferences for decision rights from aversion to strategic uncertainty. Strategic uncertainty aversion means that a decision-maker shies away from a rejectable equal split. A preference for control implies that the decision-maker is attracted to a non-rejectable equal split because she feel more in control in that case. In a simple bargaining game, they are indistinguishable.

One way to amalgamate preferences for decision rights with aversion to strategic uncertainty may be to introduce a preference for ‘having the last word.’ In other words, in the extensive game form a small positive utility component to a player’s payoff at a terminal node is added if the previous (non-terminal) decision node belongs to that player. As the model of preferences for decision rights proposed by Bartling et al. (2014), in principle such utility modeling still allows for classical Nash equilibrium analysis. However, it does come with costs. First, such preferences are inconsistent with a notion of rational players who assume that other rational players make optimal countermoves, which lies at the very core of Nash equilibrium analysis. The question then is how we can assume rational players with rational expectations about other rational players, if at the same time we assume these players to have preferences that essentially imply that they do not have such rational expectations. Second, where would such preferences for decision rights or for having the last word may come from?

---

<sup>26</sup>Note that theoretically, this design entails a similar problem as discussed for Experiment 3: Had the principals and agents known that they will later face lotteries determined by the current effort choices, they might have chosen a different level of effort in the first place. In the experiment, they did not know.

As shown in Experiment 4, players leave money on the table due to the rejectability of the equal split. In an evolutionary sense, such preferences should not survive or arise.

## VII CONCLUSIONS

The main result reported in this study is that in simple bargaining games, whether second movers can reject a fair offer plays a role for first movers, even though almost nobody rejects an equal split or believes that it would be rejected. This observation is robust across experimental designs, procedures, and subject pools, indicating some degree of internal and external validity. This behavior can lead to inefficiencies in economic interactions.

The implications of these observations are broader, as they represent a challenge to strategic decision theory. The strong notion of consistency between equilibrium beliefs and strategies in the tradition of Nash cannot capture the apparent strategic uncertainty aversion observed in the experiments reported in this paper. The potential economic transaction inefficiencies indicate a need for behavioral mechanisms and institutions that help to prevent the problem.

Admittedly, the results reported in this paper raise more questions than they answer. They suggest further exploration of how people deal with strategic risk as opposed to regular risk differently. For example, in the spirit of Bohnet and Zeckhauser (2004), the responder's move after an equal split proposal in the *Ultimatum* game could be replaced with a lottery resembling the very low frequencies of observed equal split rejections. Another challenge would be to find an experimental design that can cleanly distinguish between preferences for decision rights (or having the last word) and aversion to strategic uncertainty. Finally, in this paper I studied the basic phenomenon only in simple one-shot games. Whether the observed behavior is robust to repetition and learning is an open question.

Despite all the theoretical questions raised, one practical lesson that can be learnt from the experiments reported in this paper is that bargainers who find themselves as a responder in an Ultimatum-like situation should not only communicate to the proposer that they would *reject an unfair offer*, but also make clear that they would *accept a fair one*.

## REFERENCES

- Bartling, B., Fehr, E. and Herz, H. (2014), 'The intrinsic value of decision rights', *Econometrica* **82**(6), 2005–2039.
- Bohnet, I. and Zeckhauser, R. (2004), 'Trust, risk and betrayal', *Journal of Economic Behavior and Organization* **55**(4), 467–484.
- Bolton, G. E. and Ockenfels, A. (2000), 'ERC: A theory of equity, reciprocity and competition', *American Economic Review* **90**(1), 166–193.
- Bolton, G. E. and Zwick, R. (1995), 'Anonymity versus punishment in ultimatum bargaining', *Games and Economic Behavior* **10**(1), 95–121.
- Brandts, J. and Charness, G. (2011), 'The strategy versus the direct-response method: A first survey of experimental comparisons', *Experimental Economics* **14**(3), 375–398.
- Camerer, C. F., Ho, T.-H. and Chong, J.-K. (2002), A cognitive hierarchy theory of one-shot games: Some preliminary results, Working paper, California Institute of Technology.

- Camerer, C. F., Ho, T.-H. and Chong, J.-K. (2004), ‘A cognitive hierarchy model of games’, *Quarterly Journal of Economics* **119**(3), 861–898.
- Charness, G. and Gneezy, U. (2010), ‘Portfolio choice and risk attitudes: An experiment’, *Economic Inquiry* **48**(1), 133–146.
- Chateauneuf, A., Eichberger, J. and Grant, S. (2007), ‘Choice under uncertainty with the best and worst in mind: Neo-additive capacities’, *Journal of Economic Theory* **137**(1), 538–567.
- Costa-Gomes, M. A. and Crawford, V. P. (2006), ‘Cognition and behavior in two-person guessing games: An experimental study’, *American Economic Review* **96**(5), 1737–1768.
- Dufwenberg, M. and Kirchsteiger, G. (2004), ‘A theory of sequential reciprocity’, *Games and Economic Behavior* **47**(2), 268–298.
- Eichberger, J. and Kelsey, D. (2011), ‘Are the treasures of game theory ambiguous?’, *Economic Theory* **48**(2), 313–339.
- Eichberger, J., Kelsey, D. and Schipper, B. (2008), ‘Granny versus game theorist: Ambiguity in experimental games’, *Theory and Decision* **64**(2), 333–362.
- Falk, A. and Fischbacher, U. (2006), ‘A theory of reciprocity’, *Games and Economic Behavior* **54**(2), 293–315.
- Fehr, E., Herz, H. and Wilkening, T. (2013), ‘The lure of authority: Motivation and incentive effects of power’, *American Economic Review* **103**(4), 1325–1359.
- Fehr, E. and Schmidt, K. M. (1999), ‘A theory of fairness, competition, and cooperation’, *Quarterly Journal of Economics* **114**(3), 817–868.
- Fischbacher, U. (2007), ‘z-Tree: Zurich toolbox for ready-made economic experiments’, *Experimental Economics* **10**(2), 171–178.
- Forsythe, R., Horowitz, J. L., Savin, N. E. and Sefton, M. (1994), ‘Fairness in simple bargaining experiments’, *Games and Economic Behavior* **6**(3), 347–369.
- Gigerenzer, G., Todd, P. M. and the ABC Research Group (1999), *Simple heuristics that make us smart*, New York: Oxford University Press.
- Goeree, J. K. and Holt, C. A. (2001), ‘Ten little treasures of game theory and ten intuitive contradictions’, *American Economic Review* **91**(5), 1402–1422.
- Greiner, B. (2015), ‘Subject pool recruitment procedures: Organizing experiments with ORSEE’, *Journal of the Economic Science Association* **1**(1), 114–125.
- Güth, W., Schmittberger, R. and Schwarze, B. (1982), ‘An experimental analysis of ultimatum bargaining’, *Journal of Economic Behavior and Organization* **3**(4), 367–388.
- Haile, P., Hortaçsu, A. and Kosenok, G. (2008), ‘On the empirical content of quantal response equilibrium’, *American Economic Review* **98**(1), 180–200.
- Kilka, M. and Weber, M. (2001), ‘What determines the shape of the probability weighting function under uncertainty?’, *Management Science* **47**(12), 1712–1726.
- Levine, D. K. (1998), ‘Modeling altruism and spitefulness in experiment’, *Review of Economic Dynamics* **1**(3), 593–622.
- McKelvey, R. D. and Palfrey, T. R. (1995), ‘Quantal response equilibria for normal form games’, *Games and Economic Behavior* **10**(1), 6–38.
- McKelvey, R. D. and Palfrey, T. R. (1998), ‘Quantal response equilibria for extensive form games’, *Experimental Economics* **1**(1), 9–41.
- Nash, J. F. (1951), ‘Non-cooperative games’, *Annals of Mathematics* **54**(2), 286–295.

- Owens, D., Grossman, Z. and Fackler, R. (2014), ‘The control premium: A preference for payoff autonomy’, *American Economic Journal: Microeconomics* **6**(4), 138–161.
- Rabin, M. (1993), ‘Incorporating fairness into game theory and economics’, *American Economic Review* **83**(5), 1281–1302.
- Rosenthal, R. W. (1981), ‘Games of perfect information, predatory pricing and the chain-store paradox’, *Journal of Economic Theory* **25**(1), 92–100.
- Roth, A. E. (1977a), ‘Bargaining ability, the utility of playing a game, and models of coalition formation’, *Journal of Mathematical Psychology* **16**(2), 153–160.
- Roth, A. E. (1977b), ‘The Shapley Value as a von Neumann-Morgenstern utility’, *Econometrica* **45**(3), 657–664.
- Selten, R. (1967), Die Strategiemethode zur Erforschung eingeschränkt rationalen Verhaltens im Rahmen eines Oligopolexperimentes, *in* H. Sauermann, ed., ‘Beiträge zur Experimentellen Wirtschaftsforschung’, Tübingen: Mohr, pp. 136–168.
- Selten, R. (2001), Die konzeptionellen Grundlagen der Spieltheorie einst und jetzt, Working Paper 2/2001, Bonn Graduate School of Economics.
- Stahl, D. O. and Wilson, P. W. (1995), ‘On players’ models of other players: Theory and experimental evidence’, *Games and Economic Behavior* **10**(1), 218–254.
- von Neumann, J. and Morgenstern, O. (1944), *Theory of games and economic behavior*, Princeton: Princeton University Press.

## A SUPPLEMENTARY MATERIALS FOR EXPERIMENT 1

### A.1 Experiment 1 - Description of Procedures

In this experiment, each participant made decisions for all five games, first in the role of the proposer and then in the role of the responder. To avoid order effects in the data, the order of the five games was randomized for each participant, for both roles. To present the game in the instructions and decision forms, a box representation similar to Bolton and Zwick (1995) was used. Participants were shown a box graph like the one presented in Table 8. Participant *A* (the proposer) first chooses ‘up’ or ‘down’. Then after being informed about Participant *A*’s choice, Participant *B* (the responder) chooses ‘left’ or ‘right.’ To avoid biases the position of the subgame-perfect Nash Equilibrium (unequal split/accept) was rotated within the games.

TABLE 8: THE BOX REPRESENTATION ON THE DECISION FORMS

	left	right
up	Participant A gets: XX Euro Participant B gets: XX Euro	Participant A gets: XX Euro Participant B gets: XX Euro
down	Participant A gets: XX Euro Participant B gets: XX Euro	Participant A gets: XX Euro Participant B gets: XX Euro

In all games, the total amount was 8 Euros, and the proposers decided between an unequal split of (6.40,1.60) and an equal split of (4.00,4.00). Before knowing the actual proposal, responders decided to accept or reject for both the unequal split and the equal split, and later the respective acceptance decision was implemented. Participants were also asked for their expectation on what the majority of participants would choose in the same game and role. To avoid incentive spillovers, monetary incentives were not provided for correct predictions.<sup>27</sup> However, asking for expectations should encourage participants to think about the opponent choices.

The experiment was conducted in April 2003 in the foyer of the main student cafeteria at the University of Jena, Germany. Figure 7 shows a drawing of the physical setup of the experimental session. Participants were volunteers who were recruited by an experimenter (denoted as ‘!’ in the figure) with leaflets at the entrance of the cafeteria. They were asked to participate at an experiment with monetary reward.

A student who agreed to participate stated her name and address to experimenter ‘i’. She received a code card and a form asking for gender, age, field of study, and semester, and was then guided to a free table next to the wall. After completing the personal data form, the participant received the experimental instructions (see Appendix A.2). The participant was informed that she was not allowed to communicate with others during the experiment, except for experimenter ‘X’ if she needed to ask questions. After reading the instructions, the participant answered a short comprehension

<sup>27</sup>Providing monetary incentives for stated expectations might lead risk averse participants to hedge the strategic risks between the real game and the expectations task. For example, in the *Ultimatum* game with monetary incentives for both game and predictions, a participant may hedge risks by choosing ‘up’ as the proposer, but ‘expecting’ rejection from the responder.



FIGURE 7: THE ORGANIZATION OF THE EXPERIMENT.

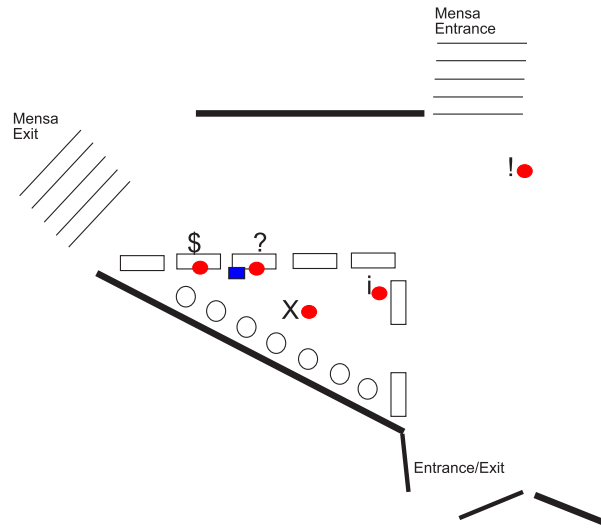

questionnaire. Once the questionnaire was answered correctly, she received the ten randomly ordered decision forms. The participant was asked to complete the decision forms one by one, from top to bottom.

After completing the forms, the participant kept her code card, put the decision forms into an envelope and dropped the envelope into a closed box. She was informed that she could pick up her experiment payoff 30-40 minutes later.<sup>28</sup>

At every 30 minutes, experimenter ‘?’ opened the box and moved the collected envelopes to a second, open box. To determine payoffs, the following procedure was used:

- First, experimenter ‘?’ randomly drew two envelopes from the box and placed them next to each other on the table.
- Second, experimenter ‘?’ threw a 10-sided die. If the number was even, then the first envelope represented the proposer and the second envelope represented the responder, and vice versa for an odd number. If the number was 1 or 2, the *Impunity* game was chosen for the determination of payoffs, if it was 3 or 4, the *Dictator* game was chosen, and *Symmetric Impunity*, *Ultimatum*, and *Reverse Impunity* were chosen for 5 or 6, 7 or 8, and 9 or 10, respectively.
- Third, experimenter ‘?’ opened both envelopes. Using the decision forms corresponding to the game and the role, the experimenter determined the choices and calculated the payoffs. Then, for each of the two participants, he wrote down the code, the game number, the role, the participant’s decision, and the opponent’s decision on a payoff form, and then gave this to experimenter ‘\$’ who handled the cash payments.
- This procedure was repeated until no more envelopes were in the open box.

<sup>28</sup>Most subjects received their cash payoff after they had lunch.

A returning participant showed her code card, signed a receipt, and received the payoff form and cash payment.

Overall, the session lasted 310 minutes, and 152 subjects participated. Five participants did not return to receive their payoff, and their data were excluded from the analysis. The remaining 147 subjects earned an average payoff of 3.74 Euro. Participants required 12 to 15 minutes on average to read the instructions, answer the questionnaire, and complete the forms.

Two participants who did not fill in the decision forms completely were also excluded from the data set. Therefore, there were 145 valid independent observations for Experiment 1. Inclusion of the excluded observations would not have changed the results.

## A.2 Experiment 1 - Instructions

### Instructions

Instructions: Code AIZ-637-S77

Welcome to this experiment. This experiment is conducted by researchers of the Max Planck Institute of Economics, Jena. Please read these instructions carefully. Then answer the comprehension questions at the end of the instructions. Signal the experimenter once you have finished.

During the experiment it is not allowed to communicate with other persons other than the experimenter. You must fill in the decision forms completely. If you do not behave according to these rules, we will have to exclude you from any payoffs.

The experiment consists of five different situations. In each situation, two participants interact with each other: Participant A and Participant B. In each situation both participants see an arrangement of 4 boxes. Each box denotes the monetary payment for Participant A and the monetary payment for Participant B. The boxes below might serve as an example:

	left	right
up	Participant A gets: .. Euro Participant B gets: .. Euro	Participant A gets: .. Euro Participant B gets: .. Euro
down	Participant A gets: .. Euro Participant B gets: .. Euro	Participant A gets: .. Euro Participant B gets: .. Euro

In each situation, first, Participant A chooses the row. That means, by choosing ‘up’ or ‘down,’ he determines if the upper or the lower row of boxes is relevant for payoffs.

After being informed about the choice of Participant A, Participant B chooses the column ‘left’ or ‘right’. Thus, he determines which box from the row chosen by Participant A is relevant for payoffs.

*Example:* Participant A chooses first. He chooses ‘up.’ Now, Participant B is informed about Participant A’s decision and chooses between ‘up/left’ and ‘up/right.’ Participant B chooses ‘left’. As a result, Participant A and B receive the payoff displayed for their role in the upper left box.

In this experiment, you’ll have to decide in all five situations. First, you will decide in all five situations in the role of Participant A. Then you will be asked for your decisions in all situations as Participant B, each time for the case that Participant A has chosen ‘up’ and for the case that Participant A has chosen ‘down’. At the end, you will have filled in 5 situations x 2 roles = 10 decision forms.

In order to calculate payoffs we will randomly match pairs of participants. Then we will randomly choose one out of the five situations, and will randomly assign the roles of ‘Participant A’ and ‘Participant B’ to the two participants. When the situation and roles are determined, the payoff simply results from the game instructions: We take the decision forms of the two participants for the selected situation. The decision of the participant in role A determines the row, and the decision of the participant in role B determines the column of the payoff box. The payoffs in this box will be paid in cash.

For the random draw to allocate the situation and roles we will take a 10-sided die. We will (randomly) take two envelopes from the box with the decision forms. Then the die is thrown once. If the number is even, then the first drawn envelope represents Participant A, and the second represents Participant B. If the number is odd, roles are assigned the other way around: the first envelope is Participant B, and the second Participant A. If the number is 1 or 2, situation 1 is selected. If it is 3 or 4, it is situation 2; if the number is 5 or 6, it is situation 3; for 7 and 8, it is situation 4; and for 9 and 10, it is situation 5.

That means, that exactly one out of the 10 decision forms you filled in will be relevant for your payoff. After you have answered the comprehension questionnaire below, you will receive a stack of decision forms. Please complete them from top to bottom. After completing all the forms, place them in the envelope and drop it in the big box. Keep the code number. You will need it to collect your payoff.

After 30-40 minutes, but at the latest at 1:30pm, please return to the experiment location. In the meantime we will randomly determine pairs, situations and roles. When you return, we will inform you about the role and situation assigned to you, and what decisions the participant matched with you has made. You will give us your code card, and we will immediately pay you in cash.

The identity of the participant matched with you will remain secret. Your identity will also be kept secret. In this sense, your decisions are anonymous.

If you have any questions now or later during the experiment, please raise your hand. An experimenter will come to you and answer your question privately.

### Comprehension questions

Questionnaire: Code AIZ-637-S77

Imagine the following situation:

	left	right
up	Participant A gets: 4 Euro Participant B gets: 4 Euro	Participant A gets: 5 Euro Participant B gets: 3 Euro
down	Participant A gets: 2 Euro Participant B gets: 6 Euro	Participant A gets: 7 Euro Participant B gets: 1 Euro

1. Assume that you are Participant B. The other person, Participant A, chooses ‘up.’ After you get to know Participant A’s decision, you choose ‘right.’ What is your actual payoff, if this situation is later randomly selected for payoff?

..... Euros

2. Assume that you are Participant A, and you choose ‘down.’ From which of the four boxes can Participant B choose now? Please mark the box(es).

.... upper left .... lower left .... upper right .... lower right

3. Assume that you are Participant A and you choose ‘down.’ Then Participant B chooses ‘left.’ What is your payoff?

..... Euros

**Proposer Decision Form**

Decision Form: Code AIZ-637-S77, Situation 5

You are Participant A. You have to choose ‘up’ or ‘down.’ Then, Participant B will choose ‘right’ or ‘left’ from the selected row.

The payoff in cash will be determined as follows:

	left	right
up	Participant A gets: 6.40 Euro Participant B gets: 1.60 Euro	Participant A gets: 6.40 Euro Participant B gets: 1.60 Euro
down	Participant A gets: 4.00 Euro Participant B gets: 4.00 Euro	Participant A gets: 4.00 Euro Participant B gets: 4.00 Euro

What do you choose? Please mark your selection: .... up .... down

What do you think the majority of all other participants will choose in this situation as Participant A? .... up .... down

**Responder Decision Form**

Decision Form: Code AIZ-637-S77, Situation 3

You are Participant B. Participant A has selected ‘up’ or ‘down.’ Now you have to choose ‘left’ or ‘right’ from the row selected by Participant A.

The payoff in cash will be determined as follows:

	left	right
up	Participant A gets: 6.40 Euro Participant B gets: 0.00 Euro	Participant A gets: 6.40 Euro Participant B gets: 1.60 Euro
down	Participant A gets: 4.00 Euro Participant B gets: 0.00 Euro	Participant A gets: 4.00 Euro Participant B gets: 4.00 Euro

If Participant A has selected ‘up’: what do you choose? Please mark your selection. .... left .... right

What do you think the majority of all other participants will choose in this situation as Participant B? .... left .... right

If Participant A has selected ‘down’: what do you choose? Please mark your selection. .... left .... right

What do you think the majority of all other participants will choose in this situation as Participant B? .... left .... right

## Personal Data Form

Personal Data Form: Code AIZ-637-S77

Gender: .... male .... female

Main field of studies: .....

Semester (including the current): .....

Age: ..... years

## B SUPPLEMENTARY MATERIALS FOR EXPERIMENT 2

### *B.1 Experiment 2 - Description of Procedures*

Participants were recruited into a large lecture hall University of Jena using the online recruitment system ORSEE (Greiner, 2015). A total of 153 participants simultaneously participated in the session in May 2005. Before the session began, participants were asked whether they had participated in Experiment 1 two years earlier, and none indicated previous participation. In addition, participation lists of both experiments were cross-checked after the experiment, and yielded no matches.

Participants were seated in the lecture hall with at least one seat between them, and were asked not to communicate with others during the session. They received instructions including a complete description of Experiment 1 and the original instructions, along with a description of their prediction task and a payoff table. After reading the instructions and answering the same comprehension questions as in Experiment 1, participants received the forms to record their predictions. As in Experiment 1, decision forms were randomly ordered, first the proposer forms, then the responder forms. Each form contained a grayed-out version of the original Experiment 1 decision form, and an extra section asking to guess the percentage of participants who have chosen up/down (left/right). Both percentages needed to sum to 100%.

After all the participants completed their forms, each participant was paid privately for one of the 15 expectation tasks, randomly selected by the throw of a die. To calculate payoffs, a simple step function which approximately mimics a quadratic scoring rule was used (refer to the payoff table in the instructions).

Due to the large experimental setup, the complete verification of the prediction forms could only be completed after the session. Of the 153 participants, 18 did not fill in the prediction forms completely, gave incorrect answers in the comprehension questionnaire, or made errors regarding the requirement that both percentages on each answer should add up to 100%. These observations were excluded from the analysis, with 135 independent observations remaining. The results would not have changed if these excluded observations had been included in the analysis.

### *B.2 Experiment 2 - Instructions*

Instructions: Code XXX-XXX-XXX

Welcome to this experiment. This experiment is conducted by researchers of the Max Planck Institute of Economics, Jena. Please read these instructions carefully.

During the experiment, it is not allowed to communicate with others. You must fill in the forms completely. If you do not behave according to these rules, we will have to exclude you from any payoffs.

For identification purposes, you been given a code number.

Your code number is XXX-XXX-XXX.

Please remember this number, and write it on top of all the forms you complete. This will allow us to pay you at the end.

In the experiment, you will be asked to predict the behavior of participants in a previous experiment. The better your prediction, that means the smaller the difference between the predicted and the actual behavior, the more money you will earn. The detailed payoff rules will be described below.

The other experiment was conducted about 2 years ago in the foyer of the main student cafeteria of this university, and 145 students participated. (That means each participant represents  $100\%/145 = \text{about } 0.7\%$  of all decisions.) Participants received the instructions included below. They answered comprehension questions, and then completed their decision forms. About 30 minutes later, participants received their cash payoff using their numbered code card.

The instructions and forms of the other experiment are included here in a grey shaded area like this:

Text

Your own instructions are printed like this text, black on white.

Now, please read the instructions of the other experiment carefully.

<< Instructions of Experiment 1, see Appendix A >>

In the following you will receive the same forms as the participants in the other experiment. Like them, you will first receive the decision forms for Participant A in random order, and then the decision forms for Participant B in random order.

The participants of the other experiment had to make 15 decisions: For each of the 5 situations as Participant A, whether they choose 'up' or 'down' (=5 decisions), and for each of the 5 situations as Participant B, whether they choose 'left' or 'right,' and this for both the case that Participant A has chosen 'up' and that Participant A has chosen 'down' (=  $5 \times 2 = 10$  decisions).

For each of the 15 decisions made by participants in the other experiment, we will ask what percentage of the participants have chosen 'up' ('left,' respectively), and what percentage have chosen 'down' ('right,' respectively), at a precision of 0.1 %. Naturally, the two percentages must add up to 100%.

For your payoff, we will randomly choose one of the 15 decisions. To do so we will throw a 20-sided die. If it shows a number from 1 to 15, the corresponding decision will be selected. If it shows a number from 16 to 20, the die will be thrown again. This will be repeated until a number between 1 and 15 appears.

Your payoff depends on how close your prediction is to the actual observed percentage of choices. We calculate the difference between your prediction and the observed percentage. Your payoff depends on this difference as follows:

Deviation from observed percentage	Payoff in Euros
0.0%	9.00
Up to 0.1%	8.50
Up to 0.5%	8.00
Up to 1.0%	7.50
Up to 5.0%	6.00
Up to 10.0%	4.00
Up to 20.0%	3.00
Up to 30.0%	2.00
More than 30.0%	0.00

Please complete the personal data form on the following page.

If you have any questions regarding the experiment, please raise your hand. An experimenter will come to your seat and answer your question. When all questions have been answered, we will distribute the decision forms.

### Form for predictions

Situation X

Decision Form		
You are Participant A. You have to choose ‘up’ or ‘down.’ Then, Participant B will choose ‘right’ or ‘left’ from the selected row.		
The payoff in cash will be determined as follows:		
	left	right
up	Participant A gets: 6.40 Euro	Participant A gets: 6.40 Euro
	Participant B gets: 1.60 Euro	Participant B gets: 1.60 Euro
down	Participant A gets: 4.00 Euro	Participant A gets: 4.00 Euro
	Participant B gets: 4.00 Euro	Participant B gets: 4.00 Euro
What do you choose? Please make a mark at your selection: .... up .... down		

What do you think: What percentage of participants has chosen ‘up’ and ‘down,’ respectively? Please state your prediction at a resolution of 0.1%. The two percentages must add up to 100%.

Question X: Up: \_\_\_\_% Down \_\_\_\_% (Sum = 100%)

## C SUPPLEMENTARY MATERIALS FOR EXPERIMENT 3

### C.1 Experiment 3 - Description of Procedures

The 4 sessions for Experiment 3 were conducted in December 2005 and January 2006 in the Computer Laboratory for Economic Research at the University of Cologne. Participants were recruited using the online recruitment system ORSEE (Greiner, 2015). A total of 214 subjects participated. When

participants arrived at the laboratory, they were asked not to sit down yet. After all the participants had arrived, each participant drew a numbered card out of a box. Using these numbers, participants were split into two groups of equal size. One group moved to the large lecture hall next door, and the other group stayed in the laboratory and took a seat at the computer terminal with their number. The group in the lecture hall was asked to wait quietly under the supervision of research assistants until they received their instructions.

The laboratory group (proposers) received experimental instructions for either the *Ultimatum* or the *Reverse Impunity* game (see Appendix C.2). Participants made their decision on the instructions sheet. They were then asked to transfer their decision to the computer screen. The computerized part of the experiment was programmed in zTree (Fischbacher, 2007). After all the participants had made their decision, instructions for the switching task were distributed (see Appendix C.2 and the explanations in the main text in Section IV). The 49 potential switching proposals were shown on the screen in random order. After all the decisions were made, the computer randomly selected one of the 49 switching proposals. For the proposers who accepted the switching offer, the *Ultimatum/Reverse Impunity* instructions/decision form was replaced with a *Dictator* form, stating the amounts of the switching proposal. Decision forms were then sent to the randomly matched responders in the lecture hall next door. Responders who received a *Dictator* form were asked to wait quietly, while those with an *Ultimatum/Reverse Impunity* offer had to make their decision. Responders were paid individually after all responders had made their decisions. At the same time, the forms with responder decisions were sent back to the laboratory room, where proposers were paid. Overall, the sessions lasted about 40 minutes.

### *C.2 Experiment 3 - Instructions*

*Instructions for the Reverse Impunity Game are printed below. Instructions for the Ultimatum Game were worded correspondingly.*

#### **Instructions**

Welcome to this experiment. Please read these instructions carefully. Please do not communicate with other participants from now on until the end of the experiment. If you have any questions, please raise your hand, and an experimenter will come to your seat and answer your question privately. Please do not write anything on this sheet except your decision. You received a separate sheet for notes.

If you do not comply with these rules we will have to exclude you from the experiment and any payoffs. In this experiment you can earn money. Your payoff will be paid to you in cash at the end of the experiment.

In the experiment, two participants interact with each other: Person A and Person B. All participants in the laboratory are Person A, and all participants in the lecture hall are Person B. The identity of the participant assigned to you will not be revealed. Your identity will also not be revealed to the other participant.



Person A makes his/her decision first. He/she can choose between ‘up’ and ‘down.’ Person B will be informed about this decision. Then, Person B can also choose between ‘up’ and ‘down.’ The corresponding payoffs are printed in the figure below. The payoffs will be paid in cash at the end of the experiment.

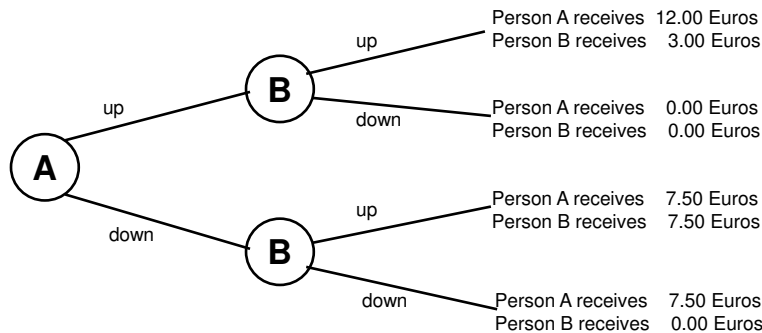

Please indicate your decision in the form below:

**Person A**

You choose between ‘up’ and ‘down.’ The Person B matched with you will then choose ‘up’ or ‘down.’ What’s your choice? Please mark your selection.

-- up -- down

**Person B**

The Person A matched with you has chosen ‘up’ or ‘down’ above. Now you choose between ‘up’ or ‘down’.

What’s your choice? Please mark your selection.

-- up -- down

**Switching offer instructions**

Before the decision form is sent to Person B, you have the opportunity to exit the experiment by accepting a fixed payoff distribution which Person B cannot change anymore.

In a moment, you will see 49 different payoff distributions at the screen, one by one. (These distributions do not always add up to 15 Euros.) Please state for each of these payoff distributions, whether you wish to exit the experiment if this distribution is offered to you.

After all the participants in the laboratory have made their decisions, for each participant, the computer will randomly select one of the 49 payoff distributions.

If you have chosen to exit the experiment for the selected payoff distribution, the payoffs will be implemented, and Person B has no decision to make. Person B will be merely be informed about the payoff distribution.

If you have chosen not to exit the experiment for the selected payoff distribution, the experiment will continue as described before. The decision form will be sent to Person B, and Person B will make his/her decision.

### Dictator replacement instructions

Welcome to this experiment. In this experiment you can earn money. Your payoff will be paid to you in cash at the end of the experiment.

Please read these instructions carefully. Please do not communicate with other participants from now on until the end of the experiment. If you have any questions, please raise your hand, and an experimenter will come to your seat and answer your question privately. Please do not write anything on the sheet except your decision. You received a separate sheet for notes.

If you do not comply with these rules, we will have to exclude you from the experiment and any payoffs.

In the experiment, two participants interact with each other: Person A and Person B. All participants in the laboratory are Person A, and all participants in the lecture hall are Person B. The identity of the participant assigned to you will not be revealed. Your identity will also not be revealed to the other participant.

Person B has no decision to make in this experiment. Person A chooses the following payoff distribution:

Person A \_\_\_\_\_ Euros, Person B \_\_\_\_\_ Euros

**Person B:** You receive the payoff denoted in the Person B field, plus your showup fee of 2.50 Euros. Please remain quiet and stay in your seat until payoffs are distributed.

## D SUPPLEMENTARY MATERIALS FOR EXPERIMENT 4

### *D.1 Experiment 4 - Description of Procedures*

The sessions of Experiment 4 were conducted in Winter 2006/07 at the Computer Laboratory for Experimental Research (CLER) at the Harvard Business School. Participants were recruited from HBS's subject pool using CLER's online recruitment system. To increase stake sizes in the experiment, participants received no show-up fee. The experiment was programmed in zTree (Fischbacher, 2007). After all participants had arrived, they received the experimental instructions, and questions were answered independently. Participants made their entry decisions on the computer screen, and if at least one of the two matched participants in a pair decided to enter the game, they made their game decision according to their role. Participants then completed a short demographics questionnaire, and were paid individually. Sessions lasted 20-30 minutes on average.

## D.2 Experiment 4 - Instructions

Instructions for the Ultimatum Game are printed below. Instructions for the Reverse Impunity Game were worded correspondingly.

### Instructions

Welcome to this experiment. Please read these instructions carefully. Please do not communicate with other participants from now on until the end of the experiment. If you have any questions, please raise your hand, and an experimenter will come to your place and answer your question privately. If you do not comply with these rules we will have to exclude you from the experiment and any payoffs. In this experiment you can earn money. Your payoff will be paid to you in cash at the end of the experiment. Note that unlike in other studies in the CLER there is no show-up fee or minimum payment in this experiment. You will only earn the payoffs which are described in the instructions below.

In this experiment we randomly form pairs of 2 participants. You will not be informed about the identity of the participant you are matched with. Similarly, the participant you are matched with will not be informed about your identity. In this sense your decisions during the experiment are anonymous.

After the groups of two participants are formed, each of the two participants is asked to choose between option Y and option Z. If both participants choose Z, each of the two participants will be paid \$20 and the experiment ends at this point (payoffs are not made until all participants have finished the experiment). If at least one of the two participants chooses Y, the experiment continues in the following way:

If one participant has chosen Y, and the other participant has chosen Z, the participant who has chosen Y will become participant A in the group, and the participant who has chosen Z will become participant B in the group. If both participants have chosen Y, the computer determines randomly which of the two participants becomes participant A and who becomes participant B.

Then, the two participants A and B interact in the following way: First participant A makes his/her decision. He/she can choose between 'up' and 'down'. Participant B will be informed about this decision. Then participant B makes his/her decision. The corresponding payoffs can be found in the figure below.

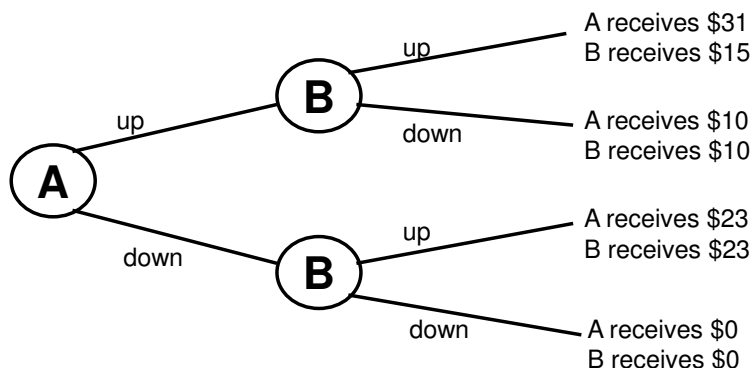

- If participant A chooses ‘up’ and subsequently, after being informed about this decision, participant B chooses ‘up’, participant A will receive \$31, and participant B will receive \$15.
- If participant A chooses ‘up’ and subsequently, after being informed about this decision, participant B chooses ‘down’, participant A will receive \$10, and participant B will receive \$10.
- If participant A chooses ‘down’ and subsequently, after being informed about this decision, participant B chooses ‘up’, participant A will receive \$23, and participant B will receive \$23.
- If participant A chooses ‘down’ and subsequently, after being informed about this decision, participant B chooses ‘down’, participant A will receive \$0, and participant B will receive \$0.

At the end of the experiment you will be paid the money you earned in the experiment in cash.